

December 2025



5G Deployment Strategy



About ASN *(boilerplate)*

Alcatel Submarine Networks, part of Nokia, leads the industry in terms of transmission capacity and installed base with more than **750,000 km of optical submarine systems deployed worldwide**, enough to go **almost 19 times around the world**.

From traditional telecom applications to content and “Webscale” service provider infrastructures, as well as to **offshore energy applications**, ASN provides **all elements of turnkey global undersea transmission systems, tailored to individual customer’s needs**.

An **extensive services portfolio** completes its comprehensive offering for the submarine business, including project management, installation and commissioning, along with marine and maintenance operations performed by **ASN’s wholly owned fleet of cable ships**.

ASN, world leader turnkey supplier for telecom submarine systems

+ 750,000 km
of submarine optical cables
deployed around the world

~ 19 times
the circumference
of the earth

+ 330,000 km
of submarine cables
under marine maintenance

7 vessels
owned & operated for
installation & maintenance

+ 160 years
of experience with
end-to-end expertise

+ 2,000
people working
worldwide



ASN worldwide presence

Headquarters

Paris-Les Ulis

Manufacturing

Calais | Greenwich | Trondheim

Cable depot | Port base

Calais | Cape Verde | Taichung

Commercial offices

Miami | Paris-Les Ulis | Trondheim

Rio | Hong Kong | Sydney

R&D and support functions

Paris-Les Ulis | Greenwich

Trondheim | Calais



ASN stakes to 5G



5G is the right choice for the long term

Reliable, scalable, sustainable and a catalyst for innovation, benefiting both ASN and its clients



A journey answering ASN challenges

1. Means



Connect all ASN core business in a coherent digital infrastructure through a real time, secure and reliable network provided by the 5G technology

- 1 Research & development
- 2 Manufacturing
- 3 Cable laying
- 4 Service life
- 5 Health, safety and ESG

3. Goal

Anticipate the market evolution and reinforce our current leadership, in a responsible and sustainable way.

2. Objectives

-  Augmenting our production capacity and speed
-  Improving our production quality and control
-  To make the work of employee more secure and with high added value





Why 5G?

Main benefits and use cases



Security

Robust encryption and authentication through USIM, enhanced device identity protection and confidentiality.



Performance & Low Latency

Multi-gigabit speeds (up to 20Gbps), extremely low-latency, and massive device connectivity (up to 1 million devices/km²).



Continuous Monitoring

Real-time analytics, edge computing for instant surveillance and diagnostics.



Bandwidth management

Networks slicing to allocate exclusive radio spectrum for specific sub-networks, improving security and performance.



Full Mobility

Seamless handover and service continuity between cells for indoor and outdoor users and at high speed.



Reliability

Ultra-high availability with robust error correction and service continuity, ideal for critical and industrial environments.

Manufacturing Execution System

#Use case

Objectif

CURRENT SITUATION

TARGET

From **paper** safety forms, work instructions and production files ...

... to nomadic, **fully digitized** and connected user interface (UI)

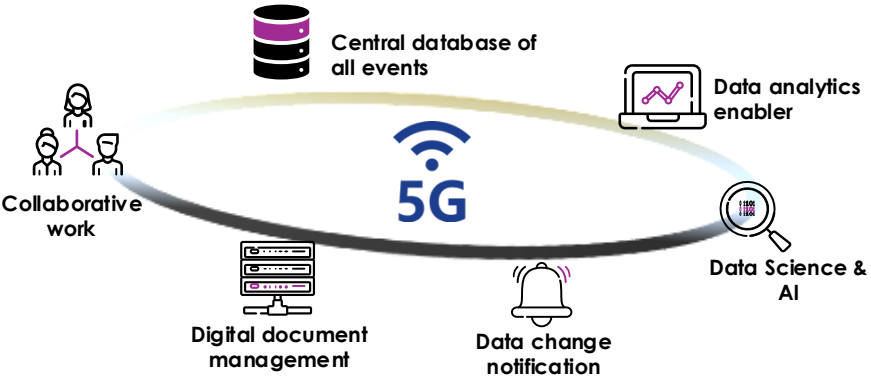
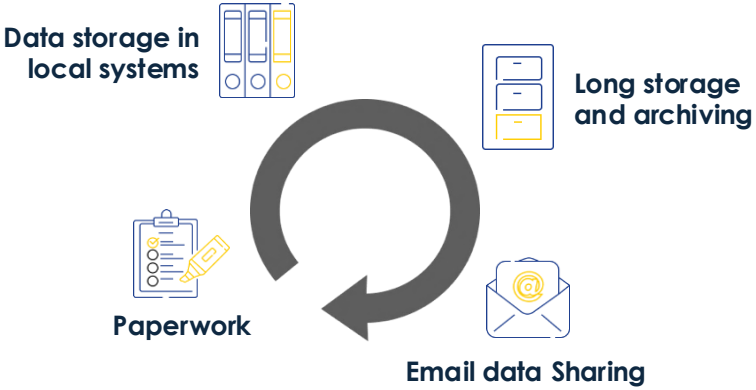

A new collaborative data sharing & management platform with 5G, MES and Data

-  Collaborative & Error-free process
-  Production files automation
-  End-to-end data traceability
-  Predictive quality enabler

IoT at Greenwich

#Use case

Objective

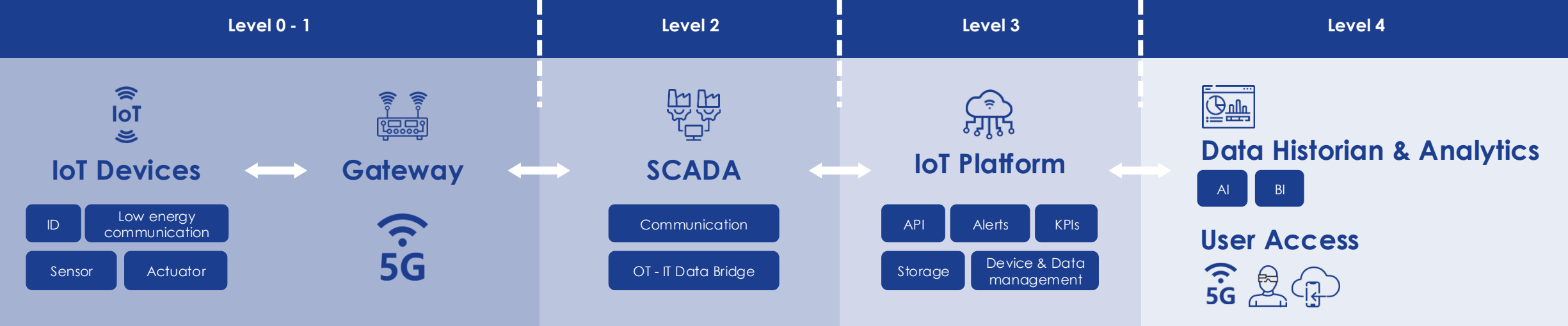

Connect IoT devices to the Data and AI world thru 5G

- IoT Device: Collects real-world data via sensors and interacts with the environment using actuators.
- 5G Connectivity: Ensures high-speed, low-latency communication between devices, gateways, and platforms.
- Gateway: Acts as a bridge, aggregating device data and forwarding it to the SCADA system.
- SCADA: Data aggregator that collects sensor/PLC data before forwarding upstream.
- IoT Platform: Provides mid-term data storage, real-time data, device management, and APIs for integration.
- User Access: End-users interact with IoT applications through dashboards, apps, or APIs.
- Data Historian: Used for large-scale analytics, archiving, and long-term storage.

Advantages

- xxxx

Telephony modernisation & critical communication #Use case

Replace the Autocom, DECT and TETRA systems with MCX and 5G smartphones integrating Teams phone

57% deployment progress

150 5G mobile phones

Advantages

Reduced maintenance costs.

Shared use of a single terminal (telephony, collaboration, PTI, alerts, etc.).

Increased reliability, security and functionality (video, photo, e-mail, etc.).

Enhanced collaboration.

Significant Return on Investment thanks to mutualisation of endpoints and infrastructure (TETRA network decommissioning for example).

Main challenges

Adoption of new equipment by users (support)

More tools = more vigilance (cyber, incidents etc...)

Anticipate authorities and operators' migration to MCX solutions



Remote site coverage

#Use case

Integration of remote site into the enterprise intranet without massive deployment of a network infrastructure

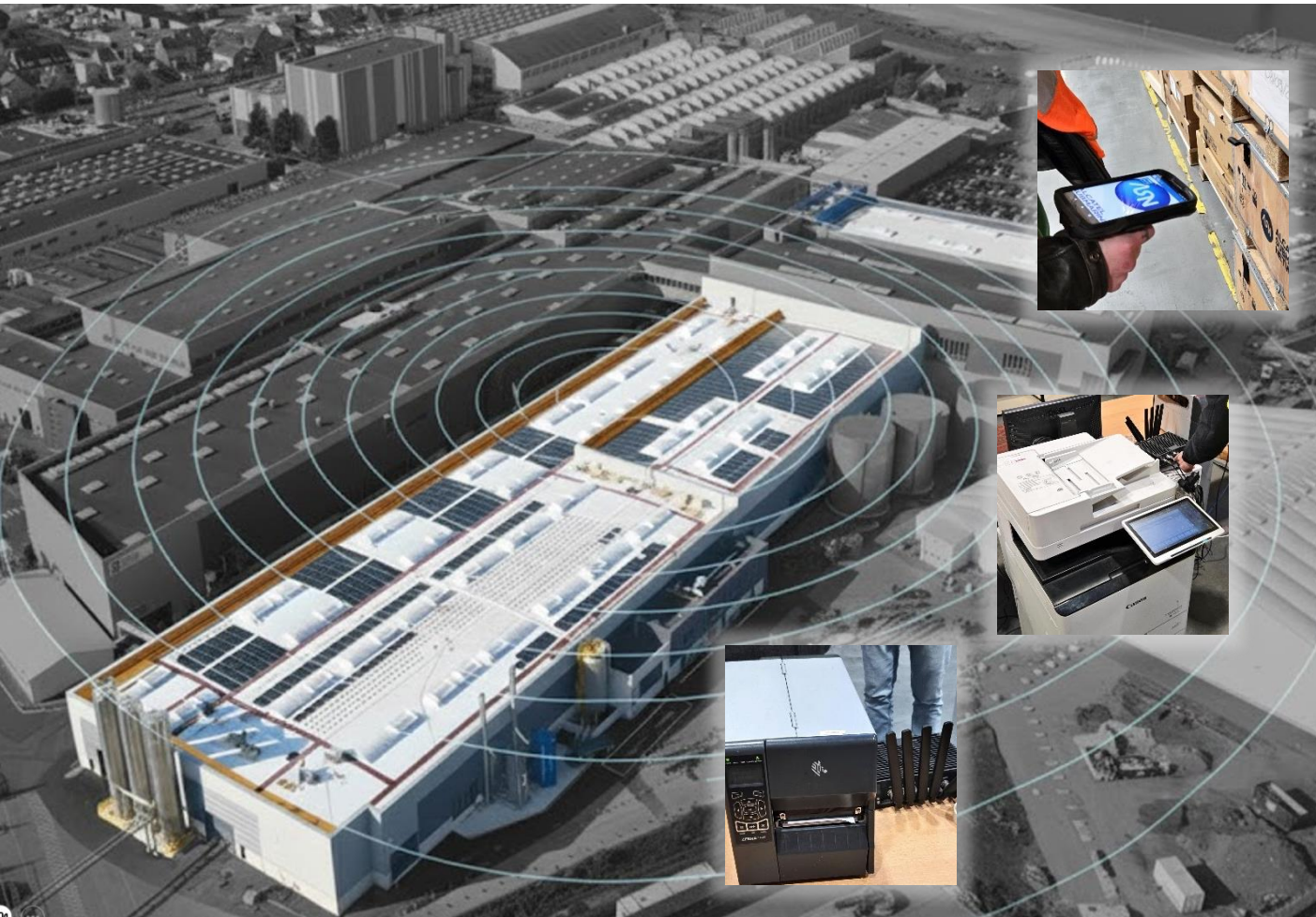

Multiple use case deployment

- QR code reading (Zebra) throughout the site
- Printer and labeler
- Camera outside the classic network infrastructure
- Remote warehouse on the industrial campus, part of the Hub, connected via 5G

Advantages

“Plug & Play” deployment of use cases thanks to the flexibility of wireless network.

Ease and speed of deployment, combined with **throughput and security** allow to deploy critical use cases in several days.

Building Management System

#Use case

Ensure best comfort on ASN sites while optimizing building management costs

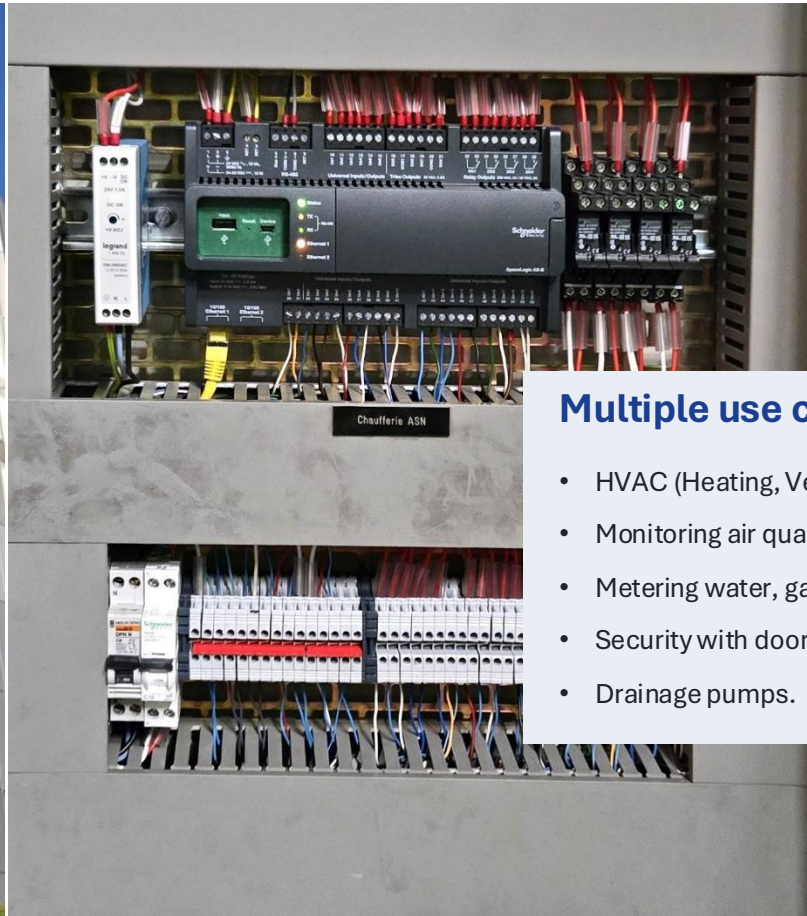

9 BMS PLCs connected in 5G

M€ Several million euros a year

Multiple use case deployment

- HVAC (Heating, Ventilation, Air Conditioning),
- Monitoring air quality, hygrometry, temperature,
- Metering water, gas etc.
- Security with door opening sensors,
- Drainage pumps.

3 other 5G use cases



Moulding press and mobile cabin

Control multiple moulding press results from a unique and mobile

- The moulding press booth is 5G-connected to enable.
- High-bandwidth 5G enables rapid transfer of large images to the NAS and operator computer.
- Reliable, high-speed data transmission supports critical measurement and production flows.

Description

Advantages

- **Improved operational performance** with real-time, high-quality data flow supporting quality and process control.
- **Enhanced mobility** eliminates static wired equipment, reducing hardware costs.
- **Increased flexibility** for operators to reposition the booth as production needs evolve.



Naveo – Emergency lighting management

Maintain emergency lighting operation in the event of a power outage.

- Centralised monitoring of all emergency lighting units in the factory through a 5G gateway and Naveo dongles (currently 9 active, 1 pending).
- Plug-and-play deployment: 5G-connected dongles install directly, avoiding any additional network cabling.

- **Rapid and non-intrusive deployment** with no need for physical network infrastructure.
- **Enhanced safety and compliance** through real-time remote status monitoring and easier preventive maintenance.
- **Improved reliability**, reducing risk during power failures.



Automated Guided Vehicle

Automate delivery of optical, mechanical and electronic components.

- Automation of deliveries between the warehouse and production line.
- Seamless integration with industrial information systems.
- End-to-end traceability of components, from storage to the assembly line.

- **Increased responsiveness** of material supplies.
- **Reduced logistics errors** enabled by full traceability.
- **Enhanced operator safety**.
- **Stock optimisation** reducing storage costs and shortages.



5G strategy

Value-driven deployment



Conducting ideation workshops with various business lines to collect needs and create a backlog of use cases.



Qualification of use cases to assess the implementation complexity and the use case's business value.



Prioritization of use cases using a matrix that considers the two previous parameters and the return on investment.



Monitoring of technologies available on the market, likely to provide high-value use cases for ASN.



5G use case assessment

Technology Dxxxxxxxxx

1

5G use case ROI

Business value	P1	P0
	P2	P1
Implementation complexity		

2

5G use case prioritization matrix

Cacul de la VOM

	2005	2019	2020	2021	2022	2023	2024	2025	2026	2027
	1	2	5	4	5	6	7	8	9	10

3

Ecosystem



Surround ourselves with **the best technological** providers, startups and consulting services providers to **sustain and accelerate the transformation.**



Build **partnerships with universities and academia** to encourage students to get involved in the industrial transformation.



Encourage the **integration of 5G connectivity** in the proposed technological solutions.

sopra steria next

NOKIA

free PRO

BSCA Partners
Unlimited Performance Provider

unitel
FRANCE

ptc

INNOFACE

Digital Accelerator

COMPANY YOU CAN TRUST
THE QUEEN'S AWARDS FOR ENTERPRISE
ALTERNATIVE FINANCE 2022

UNIVERSITY of GREENWICH

MINESnancy
ARTEM

5G deployment phases in Calais

2021

2022

2023

2024

2025

2026

Pilot

- Technology testing
- Radiation impact measurement
- Communication to works

Infrastructure deployment

- Coverage of production areas
- Indoor & Outdoor

Use cases

- Learning curve
- First use cases

Resilience enhancement

- Dual core

Expansion

- Extended coverage
- Network optimisation

Performance

- N77 Pilot
- Uplink bandwidth increase

Core	1	1	2	2	2	2
Surface covered (%)	5%	80%	80%	80%	100%	100%
Outdoor antennas (N38)	0	3	3	3	4	4
Indoor antennas (N78)	17	56	56	56	83	69
Indoor antennas (N77)	0	0	0	0	0	14

5G connectivity now available for ASN production sites

Nokia NDAC Dashboard : [See](#)

11 buildings covered

200,000 square meters

87 antennas Indoor & outdoor

2.5 & 3.4 Ghz band (Free)

391 SIM Cards

(369 Calais and 22 for Greenwich)

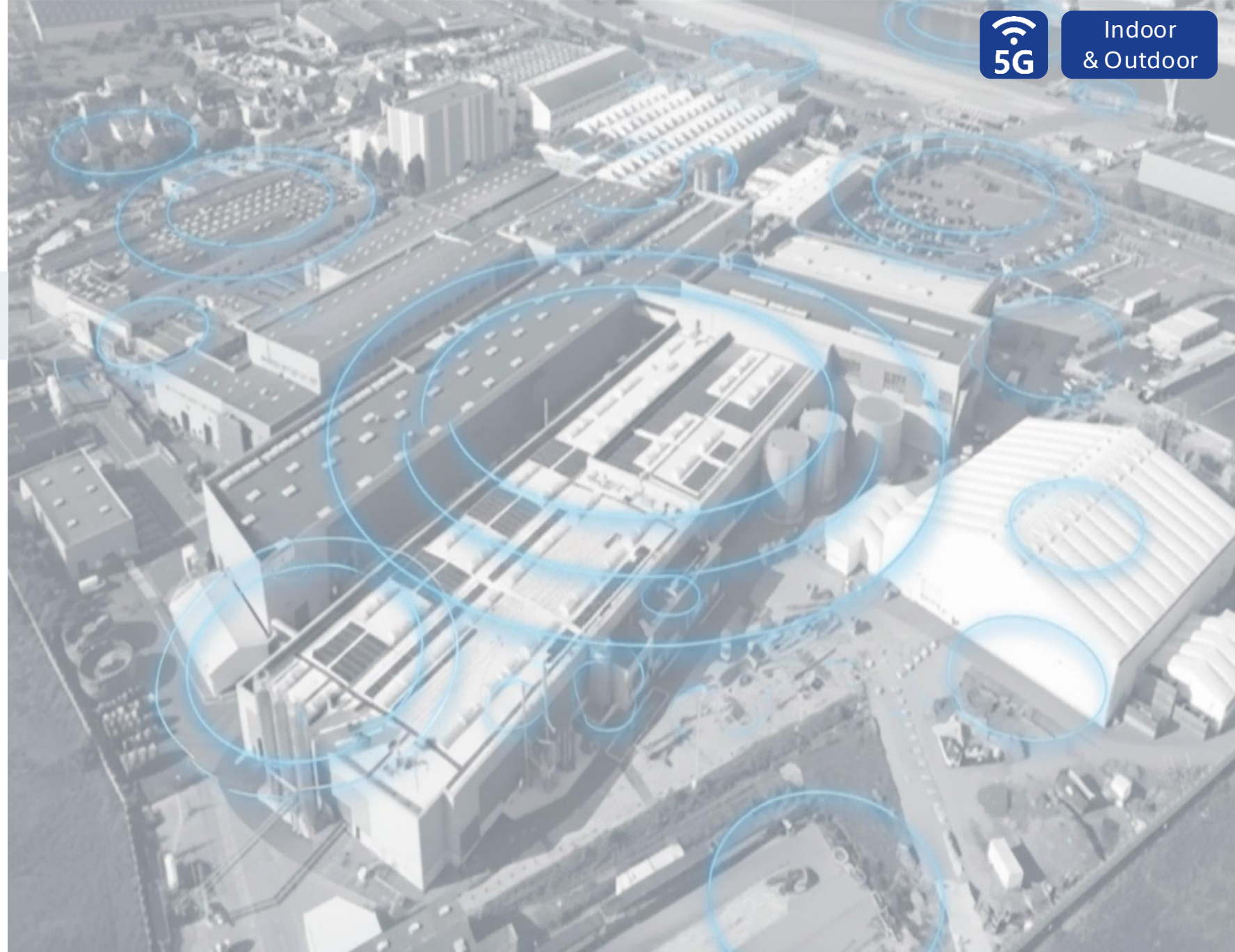





Architecture

IS&IT architecture objectives

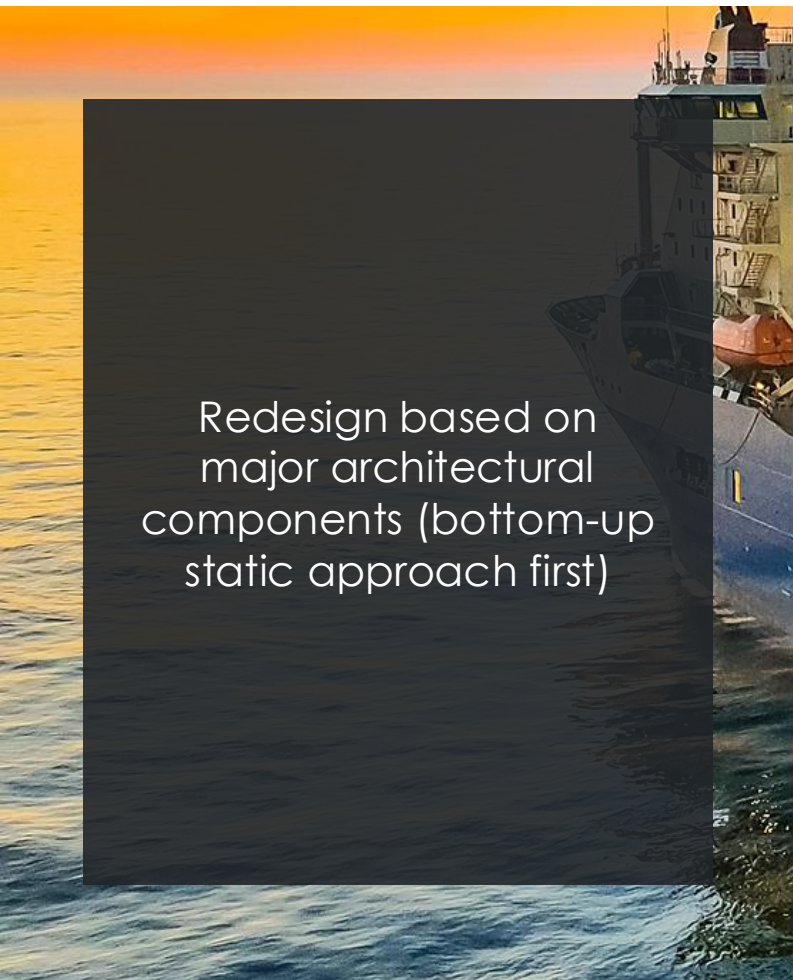
Provide a global vision of the target architecture



Redesign based on major architectural components (bottom-up static approach first)



Define the main principles of functional and technological architecture



Functional staging of the architecture to verify its application (top-down dynamic approach first)

Target IS architecture main principles

End to end business continuity

1. Most of the ASN capabilities must be covered by at least one application to ensure digital continuity between businesses
2. To ensure digital continuity, a particular importance is placed on applications that carry essential information, especially those identified as master data repository e.g. PLM carry Data products... To ensure the proper circulation of referential data within the applications, the architecture must implement a data driven service layer
3. Through IT applications, reinforce collaboration between businesses e.g. Sales & Marketing with project / project with OI / Sales with finance etc...

Unifying landscape applications and technologies

1. Rationalize "COTS" or "Bespoke" applications by highlighting their functional domain in order to form real referential systems and avoid dispersion of effort by standardizing components (Capex and Opex costs, resource skills, time to market, cloud native technologies...)
2. Develop a unified data architecture taking into account the specificities of business requirements while standardizing components with the best of breed ones

Sensitivity and data protection

1. Sovereignty must be guaranteed, in particular by preserving the confidentiality of sensitive data.
2. Inscribe the architecture towards a sovereignty cloud infrastructure that can guarantee the protection of sensitive data

Main Business constraints / functional drivers beliefs:

1. All products nomenclature (commercial products, industrial products, manufactured system project, system to be maintained ...) whatever the stage of maturity will be managed in the PLM repository
2. The contract prices of the products are formalized in an application dedicated to the quotations of the commercial opportunities in offer phase and also in project phase
3. Applications involved in financial forecasting, contractualization or quotation formalization need to integrate the evolution of product costs over time (exchange rate, inflation, material cost..)
4. The cost repository is managed in the ERP while the commercial catalog is centralized in the PLM
5. Services must be considered and traced in applications as physical products

Four architecture factors are essential to ensure a **sustainable architecture modernization** that enables ASN to better address future challenges

OT Target Architecture

5G Supporting target architecture

Onboarding 5G - Logical view / IT flow

- This view highlight the ASN specificity : 5G network will be in charge of retrieving OT data.
- The 5G network will support both IoT and legacy production equipment
- But these 2 sub-areas shall not be mixed
- 5G slicing capabilities through DNN offer a great opportunity to segregate equipment's, even if they are all using 5G
- A native segregation system is available for further deployment.
- Factory OT organization is simplified by 5G

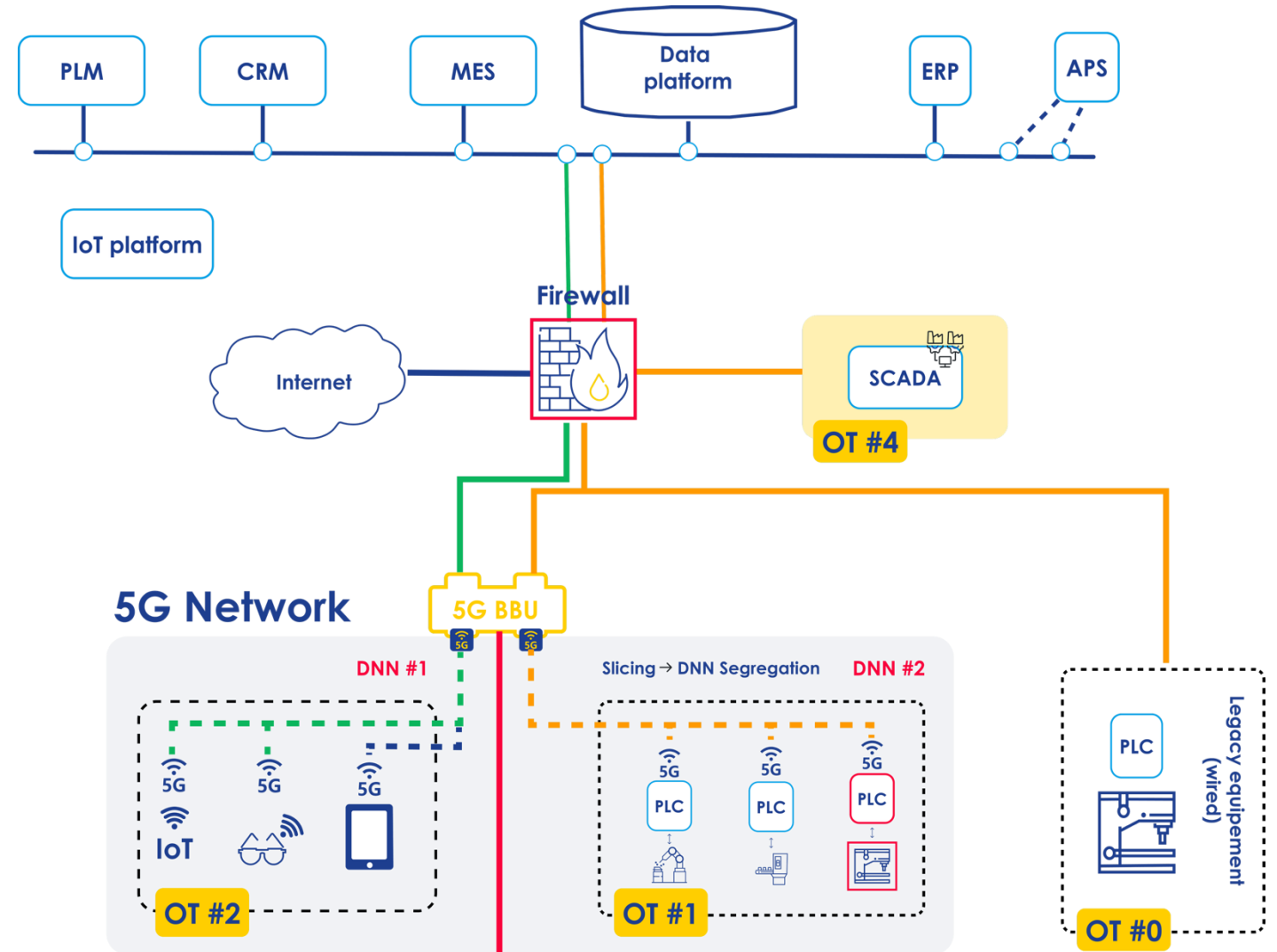

Industrial Network Security (OT) – 5G Native

End-to-End Encryption

- **3GPP-standard encryption** (AES-256, SNOW 3G, ZUC) for all traffic (u-plane, c-plane)
- **Mutual authentication** between devices and the network (via SIM/ eSIM or digital certificates)

Dedicated and Isolated Infrastructure

- Operates on **dedicated spectrum** (licensed or shared), physically or logically separated from public networks
- Eliminates risks from shared public infrastructure (e.g., no exposure to public 5G core vulnerabilities)

Granular Access Control

- **Zero Trust principles:** Strict identity verification (e.g., IMSI, IMEI, or PKI-based authentication).
- **Network slicing:** Isolates traffic by use case (e.g., IoT, voice, video) with custom security policies.

On-Premises or Hybrid Deployment

- **Localized core network** (e.g., 5G SA core on-premises) reduces exposure to external threats.
- **Edge computing** minimizes data transit over public links.

Unique (Public Land Mobile Network) ID

- **Network Isolation:** Prevents accidental roaming or cross-connection with public networks, reducing exposure to external threats
- **Access Control:** Only devices pre-configured with the private PLMN ID can connect, enforcing hardware-level authentication

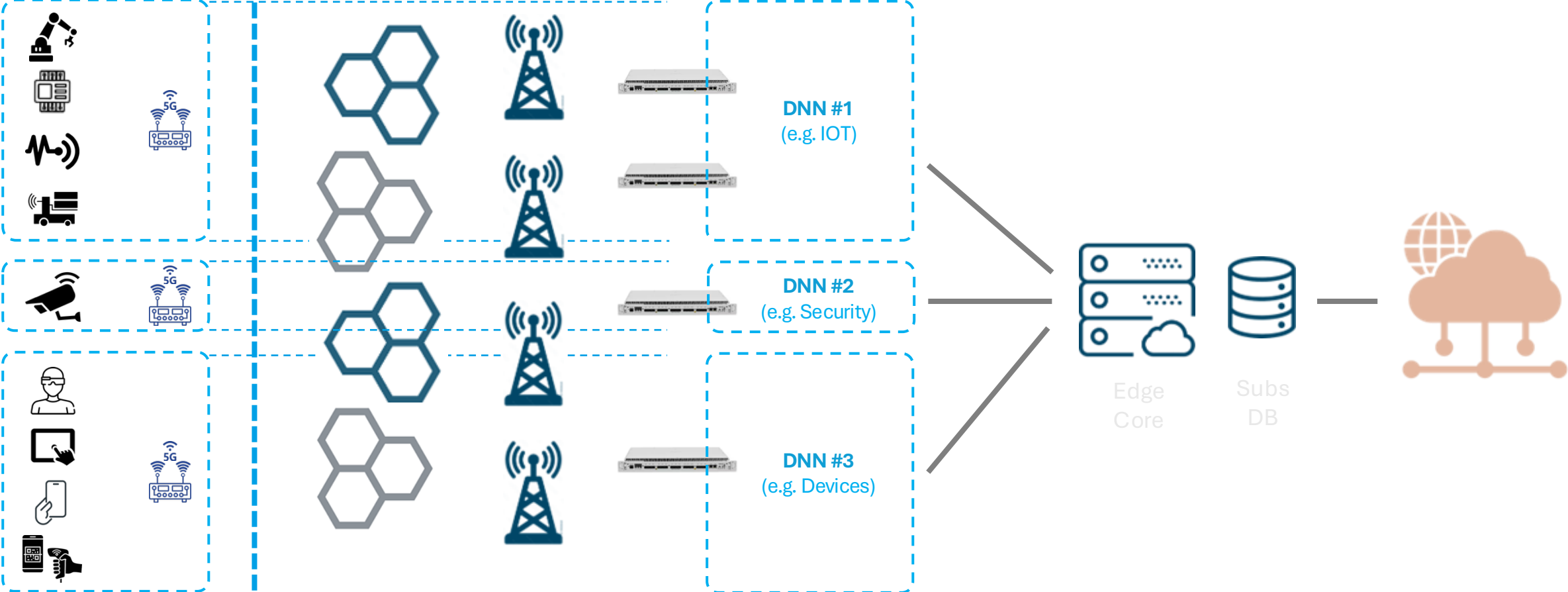

**5G is the right choice in the long term:
reliable, scalable sustainable and a
driver of innovation for ASN
and its customers.**

